

Undermount Model Double Bowl Sink DPU3119L/DPU3119R

Specifications

FEATURES:

- 18 (1.2mm) gauge nickel-bearing stainless steel
- 8" (203mm) deep
- Satin finish
- 3-1/2" (89mm) drain opening
- Sound dampening pad with spray undercoating
- Dual mount template
- Minimum cabinet size: 36" (914mm)
- Sink complies with ASME A112.19.3-2008 / CSA B45.4-08.



These sinks are listed by the International Association of Plumbing and Mechanical Officials as meeting the requirements of the Uniform Plumbing Code and the National Plumbing Code of Canada.

OPTIONAL ACCESSORIES:

- Bottom Grid: GOBG1617SS (large bowl), GOBG1115SS (small bowl)
- Drain: S1
- Mounting Brackets: RVUCLIP8 (2)

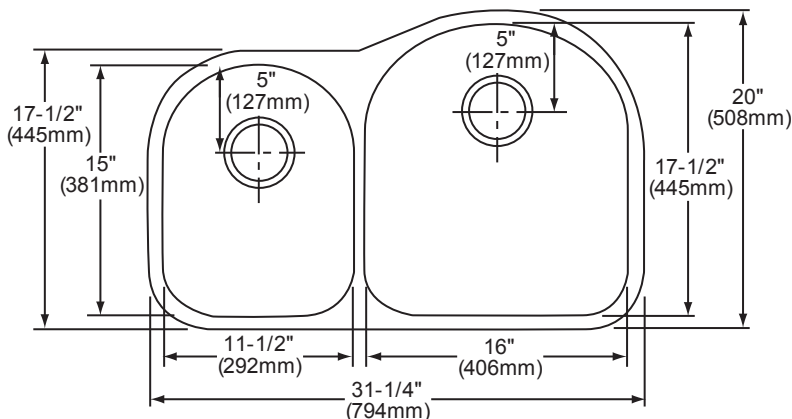

DPU3119L Illustrated

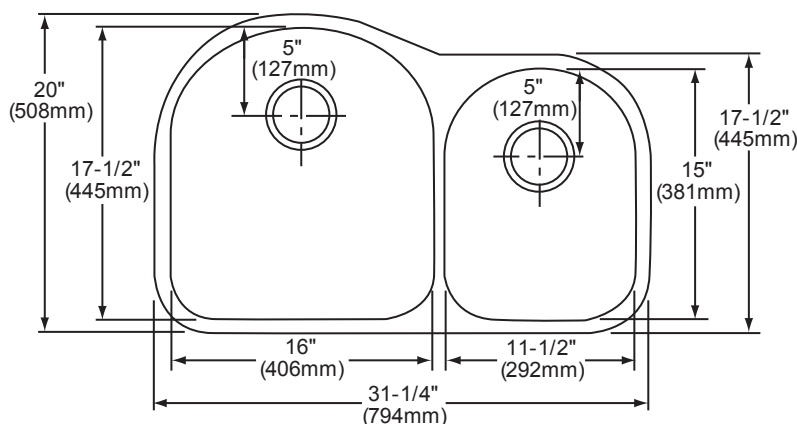

DPU3119R Illustrated

Dual Template Mounting Option

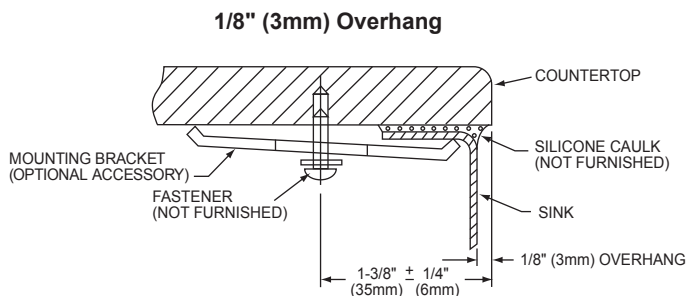
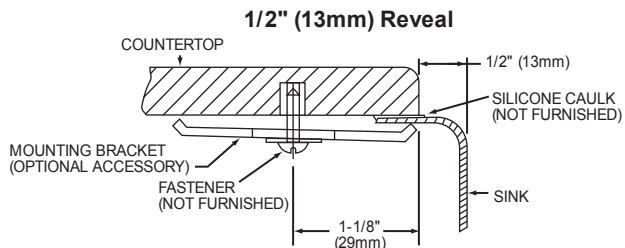

NOTE: THIS UNDERMOUNT SINK IS DESIGNED TO MOUNT TO SOLID SURFACE (NON-LAMINATE) COUNTERTOP ONLY.

In keeping with our policy of continuing product improvement, we reserve the right to change product specifications without notice.